

BUTTERFLY VALVE TYPE 57L-IS

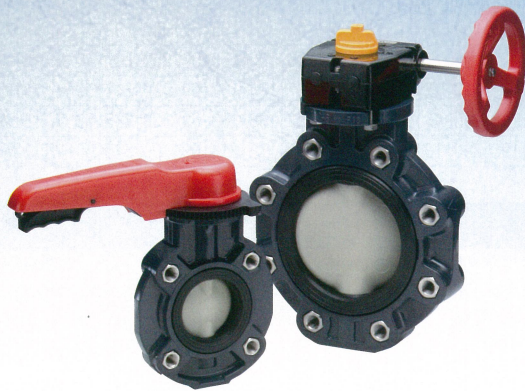

FEATURES

Short Face-to-Face Dimension

The Valves are Designed to Comply ISO5752 Short Face – to-Face dimension and allowed Replacement of Common Metal Valves.

Easy Piping Maintenance

It is not necessary to remove fluid from the pipe line.

Same Features as Type57L

SPECIFICATIONS

Body material	Standard	Working Temperature °C (°F)	Max. Working Pressure MPa{kgf/cm ² }[PSI]
Polyvinyl Chloride(PVC)	ANSI	0~50 (30~120)	1.0MPa{10.2kgf/cm ² }[150PSI]

Lever Type

DIMENSION

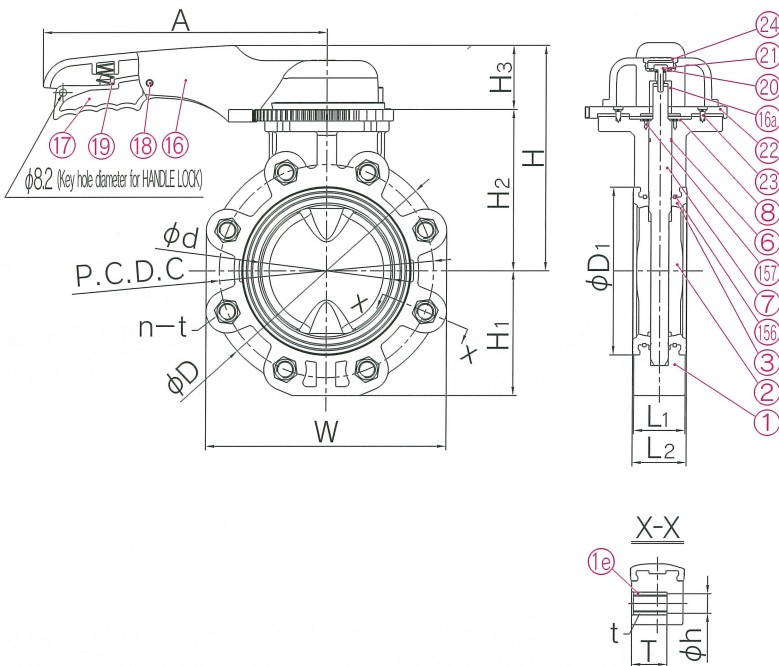

PARTS & MATERIALS

No.	DESCRIPTION	QTY.	MATERIAL
①	BODY	1	PVC
①e	LUG-INSERT		STAINLESS STEEL(SUS304) (STANDARD) STAINLESS STEEL(SUS316)
②	DISC	1	PP
③	SEAT	1	EPDM,FKM,NBR,Others
⑥	O-RING(C)	1	
⑦	STEM	1	STAINLESS STEEL(SUS403)
⑧	STEM RETAINER(A)	1	PP
⑩	HANDLE(A)	1	PP
⑩a	HANDLE INSERTED METAL	1	STAINLESS STEEL(SUS316L)
⑪	HANDLE LEVER	1	PPG
⑫	PIN	1	PPG
⑬	SPRING	1	STAINLESS STEEL(SUS304)
⑭	WASHER(A)	1	STAINLESS STEEL(SUS304)
⑮	BOLT(B)	1	STAINLESS STEEL(SUS304)
⑯	LOCKING PLATE	1	PPG
⑰	SCREW(B)	4	STAINLESS STEEL(SUS304)
⑱	CAP(A)	1	PP
⑲a	RETAINING RING	2	STAINLESS STEEL(SCS13)
⑲b	SCREW(F)	4	STAINLESS STEEL(SUS304)

DIMENSIONS TABLE

ANSI		UNIT: inch															
Nominal Size	d	ANSI150lb			D	D ₁	L ₁	L ₂	H	H ₁	H ₂	H ₃	A	W	T	t	
		C	n	h													
3	80	3.03	6.00	4	0.75	7.28	4.13	1.73	1.81	7.52	3.82	5.31	2.20	9.84	7.09	1.26	5/8-11 UNC
4	100	4.02	7.50	8	0.75	8.27	5.28	2.05	2.20	8.11	4.41	5.91	2.20	9.84	8.50	1.52	5/8-11 UNC
6	150	5.91	9.50	8	0.87	10.63	7.48	2.20	2.40	9.92	5.55	7.20	2.72	12.60	10.67	1.57	3/4-10 UNC
8	200	7.68	11.75	8	0.87	12.60	9.53	2.36	2.66	11.14	6.61	8.43	2.72	15.75	12.76	1.57	3/4-10 UNC

Gear Type

DIMENSION

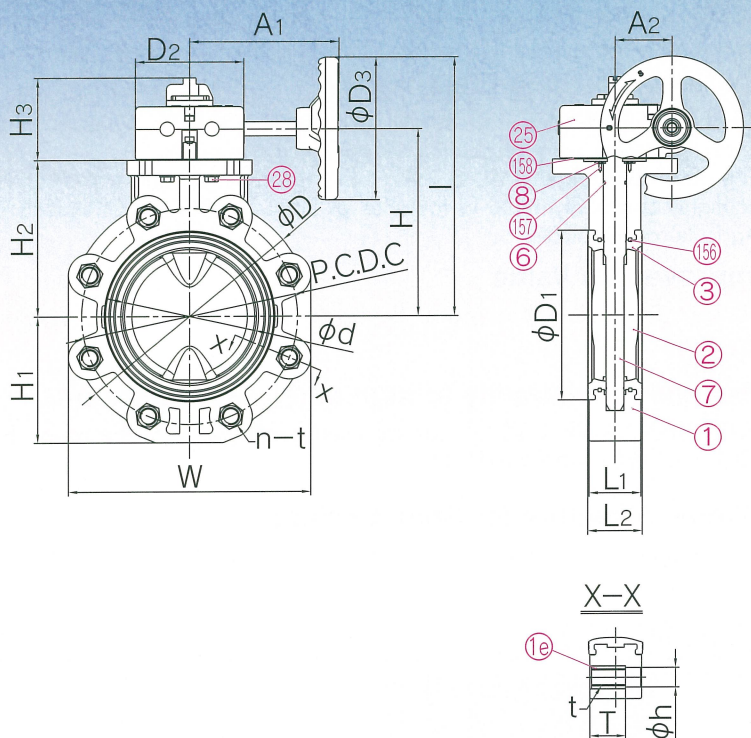

PARTS & MATERIALS

No.	DESCRIPTION	QTY.	MATERIAL
①	BODY	1	PVC
⑫	LUG-INSERT		STAINLESS STEEL(SUS304) (STNDARD) STAINLESS STEEL(SUS316)
②	DISC	1	PP
③	SEAT	1	EPDM,FKM,NBR,Others
⑥	O-RING(C)	1	
⑦	STEM	1	STAINLESS STEEL(SUS316)
⑧	STEM RETAINER(A)	1	PP
⑳	GEAR BOX	1	PLASTIC etc.
㉑	BOLT(C)	4	STAINLESS STEEL(SUS304)
㉒	RETAINING RING	2	STAINLESS STEEL(SCS13)
㉓	SCREW(F)	4	STAINLESS STEEL(SUS304)
㉔	GASKET(L)	1	EPDM

DIMENSIONS TABLE

ANSI																					UNIT: inch	
Nominal Size inch mm	d	ANSI 150lb			D	D ₁	D ₂	D ₃	L ₁	L ₂	H	H ₁	H ₂	H ₃	I	A ₁	A ₂	W	T	t	Number of handle wheel rotation	GEAR BOX TYPE
		C	n	h																		
3 80	3.03	6.00	4	0.75	7.28	4.13	4.80	6.30	1.73	1.81	6.50	3.82	5.12	3.62	9.65	6.57	2.52	7.09	1.26	5/8-11 UNC	9.5	TYPE1
4 100	4.02	7.50	8	0.75	8.27	5.28	4.80	6.30	2.05	2.20	7.09	4.41	5.71	3.62	10.24	6.57	2.52	8.50	1.52	5/8-11 UNC		
6 150	5.91	9.50	8	0.87	10.63	7.48	4.80	6.30	2.20	2.40	8.27	5.55	6.89	3.62	11.42	6.57	2.52	10.67	1.57	3/4-10 UNC		
8 200	7.68	11.75	8	0.87	12.60	6.53	4.80	6.30	2.36	2.66	9.49	6.61	8.11	3.62	12.64	6.57	2.52	12.76	1.57	3/4-10 UNC		